



# 2024 Has a Strong Outlook for Dumpster Rental Franchises

Bin There Dump That has continued to stand out in the dumpster rental franchise industry as a top affordable franchising option - we've even been recognized by the publication Entrepreneur Magazine for our financially friendly franchising options.

If you're an entrepreneur looking to start your next business venture, a dumpster rental franchise might not be the first option that comes to mind. However, perhaps owning a waste removal business should be a top investment considering its strong market - both currently and for the foreseeable future.

Most construction projects, whether residential or commercial, require a dumpster rental solution that can accommodate a significant amount of generated waste. With the number of these construction projects on the rise, the demand for a professional dumpster rental company to handle waste removal needs should also stay high.

Bin There Dump That has earned our reputation as America's favorite dumpster rental company thanks to the high-quality bins and outstanding customer service we provide. Our dumpsters prove their value to many construction projects, and our Franchise Operators are the ones best positioned to make the most of this demand in a recession-resistant industry. We utilize a Simple and Friendly business model that delivers exactly what many customers want and other junk disposal companies lack: high-quality dumpster bins with stellar customer service!



## Home Renovations Create Strong Demand

Today's housing market has seen many homeowners increase their efforts to maximize their property's value. Higher-than-normal interest rates and overall economic concerns have motivated many homeowners to stay put longer than originally planned and instead opt for investing in home improvements.

As the 2024 calendar year approaches the halfway mark, property owners continue to increase their spending on home services. The **2023 State of Home Spending Report** revealed that homeowners spent an average of over \$13,000 on their home improvement and repair projects last year. Another notable statistic in the report reveals that the average home underwent 11 projects over the course of 2023.

The report also cites 40 percent of homeowners stating that they took on more home improvement work due to rising interest rates, making moving or finding a new home a less feasible option. These numbers suggest a positive outlook for dumpster rental companies in 2024 and beyond - particularly ones with greater brand recognition among potential customers looking to improve their homes.

Bin There Dump provides a low-cost franchise opportunity to help you hit the ground floor running. We've even been recognized by the industry publication **Entrepreneur Magazine** for our affordable franchising opportunities. We can help you build a dream and set realistic financial goals while doing so.



## Commercial Properties Undergoing Major Changes

Commercial properties have witnessed significant fluctuations in value in recent years as employee and consumer preferences have shifted. This has motivated organizational leaders, business owners, and property managers to undergo construction projects to enhance their properties' current condition by updating, expanding, or reconfiguring to provide a more accommodating, appealing, and better-functioning environment.

Plenty of commercial properties exist outside of major urban areas. In fact, businesses and organizations are increasingly willing to break ground in areas outside cities to build and provide better commutable access for non-city dwellers. A dumpster rental company like Bin There Dump can prove to be an incredibly valuable partner for those looking to build or improve their commercial properties.

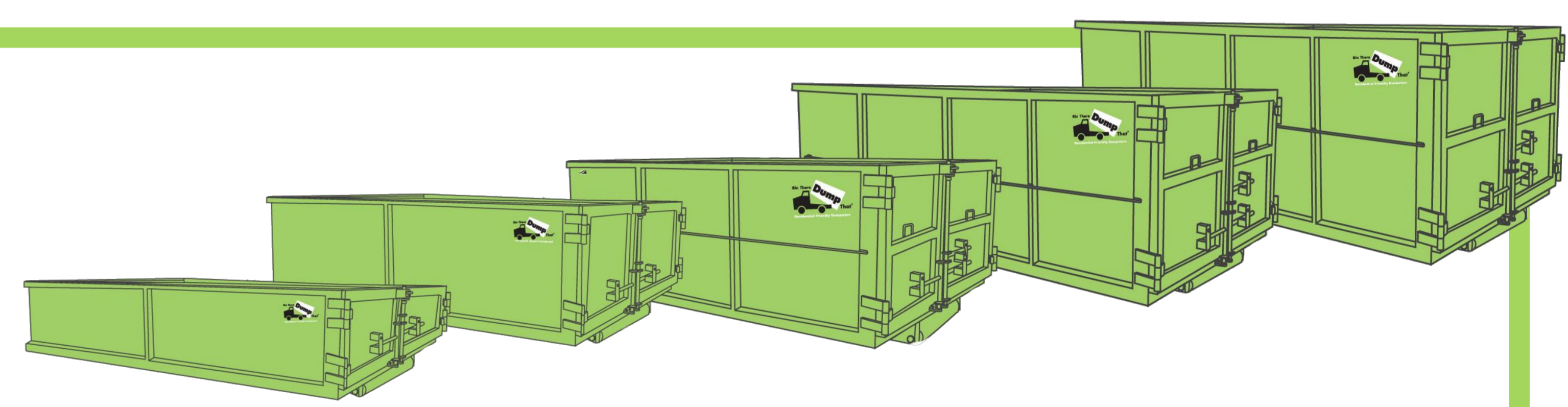

Partnering with Bin There Dump That, customers can feel confident knowing they can rely on our trusted local waste disposal solutions to help keep projects, big or small, running smoothly and on time.

Becoming a Bin There Dump That Franchise Operator offers fantastic opportunities to leverage the high demand for waste removal services among a variety of customers. Our team is eager to add motivated professionals who are ready to bring our Simple and Friendly franchise model to their neighborhoods and communities. With us by your side, you can feel confident in your ability to live up to Bin There Dump That's stellar reputation as America's favorite dumpster rental!



Discover why a Bin There Dump That franchise is one of the best investments you can make in 2024 and beyond by visiting our website!

